

TEREX AC120/4J

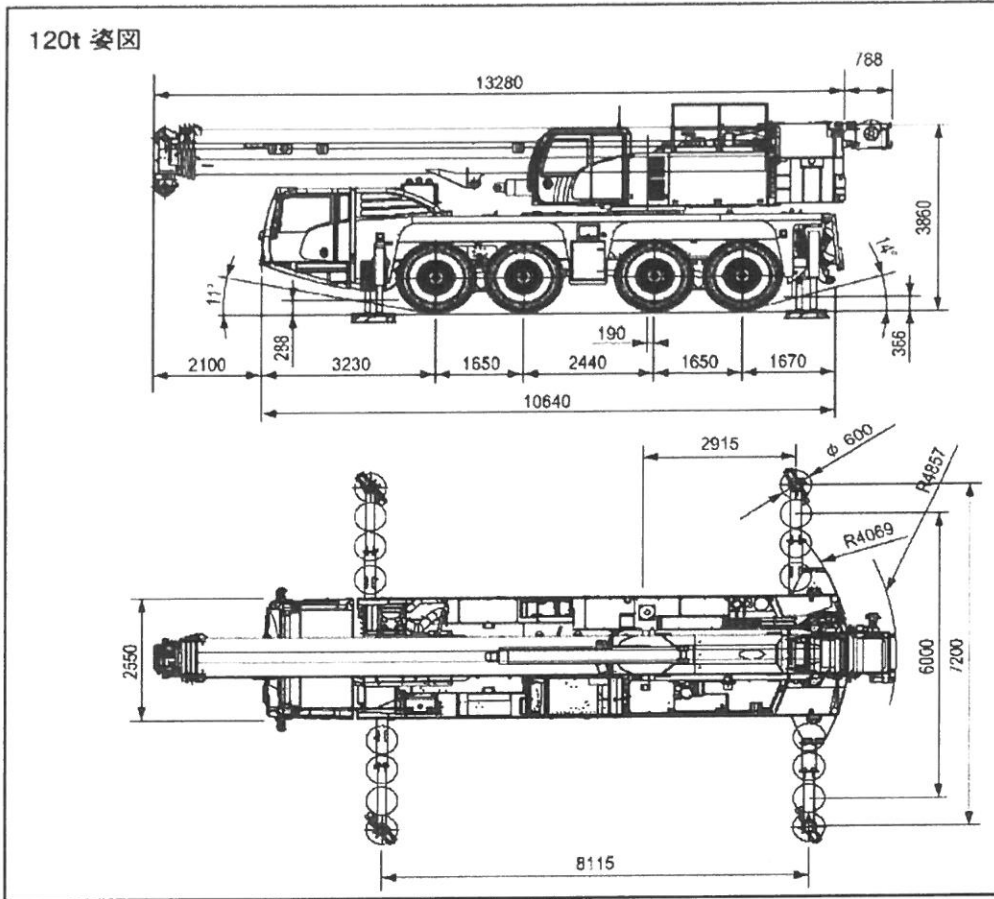

走行軌跡図

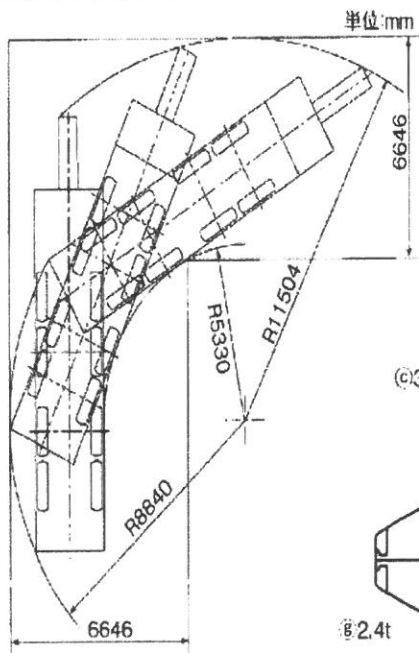

カウンターウェイト

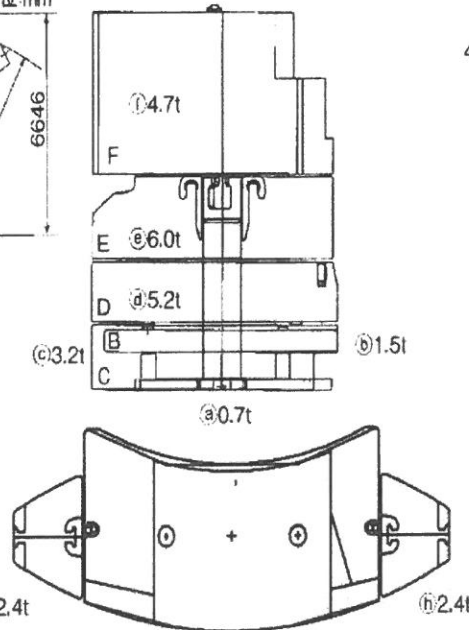

フックブロック

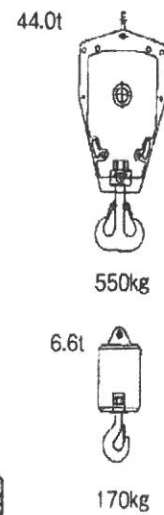

TEREX AC120/4J

■メインブーム作業半径-揚程図

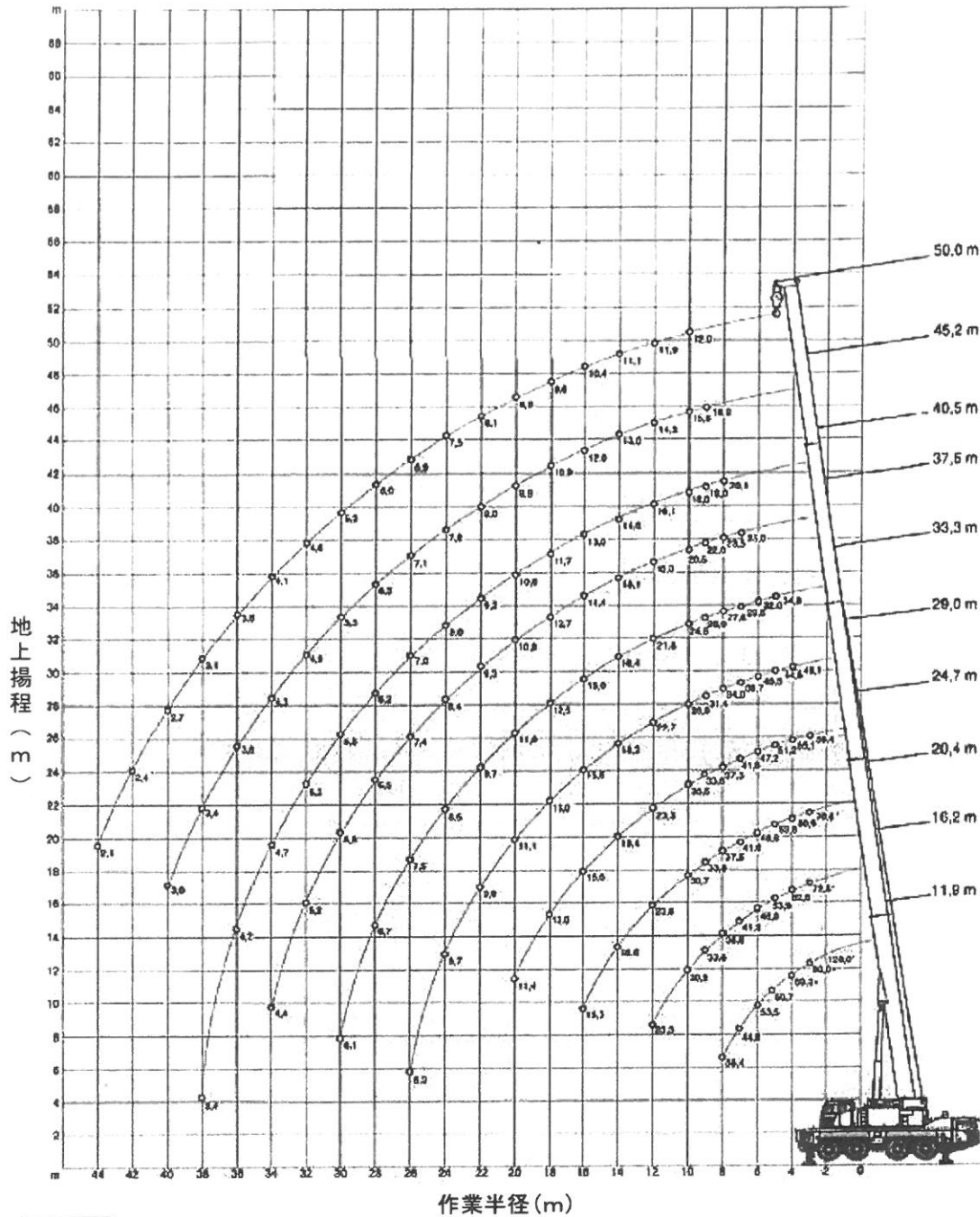

注意

1. 定格総荷重はフックブロック、玉掛ワイヤー等の自重を含みます。
また、下記の条件が考慮されていないのでクレーンの操作には充分気をつけてください。
 - ① 地盤の強度、地震による影響。
 - ② 作業速度に応じた動荷重および台風または強風による影響等。
2. 本機は水平に設置して、クレーン作業を行ってください。
3. 作業半径は、クレーンの旋回中心から荷重の重心までの水平距離です。

TEREX AC120/4J

メインブーム定格総荷重表

アウトリガ7.2m張出

26.1 t		8.10 m x 7.20 m											360°		ISO
(0°)															
11.9m		11.9m	16.2m	20.4m	24.7m	29.0m	33.3m	37.5m	40.5m	45.2m	50.0m				
m		t	t	t	t	t	t	t	t	t	t	m		m	
3	120.0*	80.0*	74.2*	72.5*	70.6*	58.0	-	-	-	-	-	-	3	3	
4		69.3*	62.7	62.8	60.9	54.5	48.1	-	-	-	-	-	4	4	
5		60.7	53.4	53.9	53.6	51.2	44.5	34.8	-	-	-	-	5	5	
6		53.5	46.3	46.9	46.8	47.2	40.5	32.0	-	-	-	-	6	6	
7		44.8	40.8	41.3	41.9	41.8	36.7	29.6	25.0	-	-	-	7	7	
8		38.4	36.3	36.8	37.5	37.3	34.0	27.6	23.5	20.1	-	-	8	8	
9		-	-	33.6	33.8	33.6	31.4	26.0	22.0	19.0	16.2	-	9	9	
10		-	-	30.5	30.7	30.5	28.8	24.6	20.5	18.0	15.6	12.0	10	10	
12		-	-	23.3	23.5	23.3	22.7	21.8	18.3	16.1	14.3	11.9	12	12	
14		-	-	-	18.6	18.4	18.2	18.4	16.1	14.6	13.0	11.1	14	14	
16		-	-	-	15.3	15.0	15.5	15.0	14.4	13.0	12.0	10.4	16	16	
18		-	-	-	8.8	13.0	13.0	12.5	12.7	11.7	10.9	9.6	18	18	
20		-	-	-	-	11.4	11.1	11.0	10.8	10.6	9.9	8.8	20	20	
22		-	-	-	-	8.8	9.6	9.7	9.3	9.2	9.0	8.1	22	22	
24		-	-	-	-	-	8.7	8.5	8.4	8.0	7.8	7.5	24	24	
26		-	-	-	-	-	6.3	7.5	7.4	7.0	7.1	6.9	26	26	
28		-	-	-	-	-	-	6.7	6.5	6.2	6.3	6.0	28	28	
30		-	-	-	-	-	-	6.1	5.8	5.8	5.5	5.3	30	30	
32		-	-	-	-	-	-	-	5.2	5.3	4.9	4.6	32	32	
34		-	-	-	-	-	-	-	4.4	4.7	4.3	4.1	34	34	
36		-	-	-	-	-	-	-	-	4.2	3.8	3.6	36	36	
38		-	-	-	-	-	-	-	-	3.4	3.4	3.1	38	38	
40		-	-	-	-	-	-	-	-	-	3.0	2.7	40	40	
42		-	-	-	-	-	-	-	-	-	-	2.4	42	42	
44		-	-	-	-	-	-	-	-	-	-	2.1	44	44	

21.3 t		8.10 m x 7.20 m											360°		ISO
11.9m		16.2m	20.4m	24.7m	29.0m	33.3m	37.5m	40.5m	45.2m	50.0m					
m		t	t	t	t	t	t	t	t	t	m		m		
3		74.0*	72.5*	70.6*	58.4	-	-	-	-	-	-	-	3	3	
4		62.1	62.6	60.9	55.1	48.1	-	-	-	-	-	-	4	4	
5		52.9	53.4	53.3	51.2	44.5	34.8	-	-	-	-	-	5	5	
6		45.9	46.4	46.3	46.8	40.5	32.0	-	-	-	-	-	6	6	
7		40.3	40.9	41.5	41.3	36.7	29.6	25.0	-	-	-	-	7	7	
8		35.9	36.6	37.1	36.9	34.0	27.6	23.5	20.1	-	-	-	8	8	
9		-	32.9	33.1	32.9	30.9	26.0	22.0	19.0	16.2	-	-	9	9	
10		-	27.6	27.9	27.7	27.1	24.6	20.5	18.0	15.6	12.0	-	10	10	
12		-	20.7	20.9	20.7	20.4	20.7	18.3	16.1	14.3	11.9	-	12	12	
14		-	-	16.5	16.4	16.8	16.2	15.8	14.6	13.0	11.1	-	14	14	
16		-	-	13.9	13.9	13.7	13.5	13.4	12.7	12.0	10.4	-	16	16	
18		-	-	8.8	11.7	11.5	11.6	11.1	11.1	10.8	9.6	-	18	18	
20		-	-	-	10.0	10.1	9.8	9.7	9.4	9.1	8.8	-	20	20	
22		-	-	-	8.7	8.7	8.5	8.3	8.0	8.1	7.8	-	22	22	
24		-	-	-	-	7.6	7.5	7.3	7.2	7.0	6.8	-	24	24	
26		-	-	-	-	6.3	6.6	6.4	6.4	6.1	5.8	-	26	26	
28		-	-	-	-	-	5.8	5.6	5.7	5.3	5.0	-	28	28	
30		-	-	-	-	-	5.2	4.9	5.0	4.6	4.4	-	30	30	
32		-	-	-	-	-	-	4.4	4.4	4.0	3.8	-	32	32	
34		-	-	-	-	-	-	3.6	3.9	3.5	3.3	-	34	34	
36		-	-	-	-	-	-	-	3.5	3.1	2.8	-	36	36	
38		-	-	-	-	-	-	-	2.7	2.7	2.4	-	38	38	
40		-	-	-	-	-	-	-	-	2.4	2.1	-	40	40	
42		-	-	-	-	-	-	-	-	-	1.8	-	42	42	
44		-	-	-	-	-	-	-	-	-	1.5	-	44	44	

1. 定格総荷重は、本体を水平堅土上に設置し、フックブロックの自重を含む。
2. 作業半径は、クレーンの旋回中心から荷重の重心までの水平距離です。

TEREX AC120/4J

メインブーム定格総荷重表

アウトリガ6.0m張出

26.1 t		8.10 m x 6.00 m										360°		ISO
		11.9m	16.2m	20.4m	24.7m	29.0m	33.3m	37.5m	40.5m	45.2m	50.0m			
m	t	t	t	t	t	t	t	t	t	t	t	m		
3	71.3*	71.8*	70.6*	58.4	-	-	-	-	-	-	-	3		
4	59.6	60.1	60.0	55.1	48.1	-	-	-	-	-	-	4		
5	51.0	51.5	51.4	51.2	44.5	34.8	-	-	-	-	-	5		
6	44.3	44.8	45.4	45.2	40.5	32.0	-	-	-	-	-	6		
7	38.8	39.4	40.0	39.8	36.7	29.6	25.0	18.2	-	-	-	7		
8	33.6	35.1	35.4	35.1	33.6	27.6	23.5	20.1	-	-	-	8		
9	-	28.7	29.0	28.7	28.2	26.0	22.0	19.0	16.2	-	-	9		
10	-	24.1	24.4	24.2	23.6	24.2	20.5	18.0	15.6	12.0	10	10		
12	-	18.1	18.3	18.5	18.6	18.1	17.8	16.1	14.3	11.9	12	12		
14	-	-	14.8	14.9	14.7	14.8	14.4	13.8	13.0	11.1	14	14		
16	-	-	12.2	12.2	12.3	12.1	12.0	11.7	11.4	10.4	16	16		
18	-	-	8.8	10.2	10.3	10.1	10.0	9.7	9.8	9.5	18	18		
20	-	-	-	8.8	8.8	8.7	8.5	8.6	8.3	8.0	20	20		
22	-	-	-	7.7	7.6	7.5	7.3	7.4	7.1	6.9	22	22		
24	-	-	-	-	6.7	6.6	6.4	6.4	6.1	5.9	24	24		
26	-	-	-	-	5.9	5.8	5.6	5.6	5.3	5.1	26	26		
28	-	-	-	-	-	5.1	4.9	5.0	4.7	4.5	28	28		
30	-	-	-	-	-	-	4.5	4.3	4.4	4.1	3.9	30	30	
32	-	-	-	-	-	-	-	3.9	3.9	3.6	3.4	32	32	
34	-	-	-	-	-	-	-	3.2	3.5	3.2	3.0	34	34	
36	-	-	-	-	-	-	-	-	3.1	2.8	2.6	36	36	
38	-	-	-	-	-	-	-	-	2.5	2.5	2.3	38	38	
40	-	-	-	-	-	-	-	-	-	2.2	2.0	40	40	
42	-	-	-	-	-	-	-	-	-	-	1.7	42	42	
44	-	-	-	-	-	-	-	-	-	-	1.4	44	44	

21.3 t		8.10 m x 6.00 m										360°		ISO
		11.9m	16.2m	20.4m	24.7m	29.0m	33.3m	37.5m	40.5m	45.2m	50.0m			
m	t	t	t	t	t	t	t	t	t	t	t	m		
3	70.7*	71.2*	70.6*	58.4	-	-	-	-	-	-	-	3		
4	59.2	59.6	59.6	55.1	48.1	-	-	-	-	-	-	4		
5	50.6	51.1	51.0	51.2	44.5	34.8	-	-	-	-	-	5		
6	43.7	44.2	44.8	44.7	40.5	32.0	-	-	-	-	-	6		
7	37.8	39.3	39.5	38.4	34.6	29.6	25.0	18.2	-	-	-	7		
8	29.5	31.0	31.3	31.0	29.4	27.6	23.5	20.1	-	-	-	8		
9	-	25.3	25.6	25.3	24.9	24.7	22.0	19.0	16.2	-	-	9		
10	-	21.2	21.5	21.7	21.8	21.3	19.8	18.0	15.6	12.0	10	10		
12	-	15.8	16.5	16.6	16.3	16.5	16.0	15.3	14.3	11.9	12	12		
14	-	-	13.0	13.1	13.2	13.0	12.8	12.5	12.2	11.1	14	14		
16	-	-	10.6	10.8	10.7	10.6	10.4	10.4	10.2	9.9	16	16		
18	-	-	-	9.0	9.0	8.9	8.7	8.7	8.4	8.2	18	18		
20	-	-	-	7.6	7.7	7.5	7.3	7.4	7.1	6.8	20	20		
22	-	-	-	6.6	6.6	6.4	6.2	6.3	6.0	5.8	22	22		
24	-	-	-	-	5.8	5.6	5.4	5.4	5.1	4.9	24	24		
26	-	-	-	-	5.1	4.9	4.7	4.7	4.4	4.2	26	26		
28	-	-	-	-	-	4.3	4.1	4.1	3.8	3.6	28	28		
30	-	-	-	-	-	-	3.8	3.6	3.6	3.3	3.1	30	30	
32	-	-	-	-	-	-	-	3.2	3.2	2.9	2.7	32	32	
34	-	-	-	-	-	-	-	-	2.8	2.5	2.3	34	34	
36	-	-	-	-	-	-	-	-	2.5	2.2	2.0	36	36	
38	-	-	-	-	-	-	-	-	-	1.9	1.7	38	38	
40	-	-	-	-	-	-	-	-	-	1.6	1.4	40	40	
42	-	-	-	-	-	-	-	-	-	-	1.1	42	42	
44	-	-	-	-	-	-	-	-	-	-	0.8	44	44	

1. 定格総荷重は、本体を水平堅土上に設置し、フックブロックの自重を含む。
2. 作業半径は、クレーンの旋回中心から荷重の重心までの水平距離です。

TEREX AC120/4J

■補助ジブ作業半径-揚程図

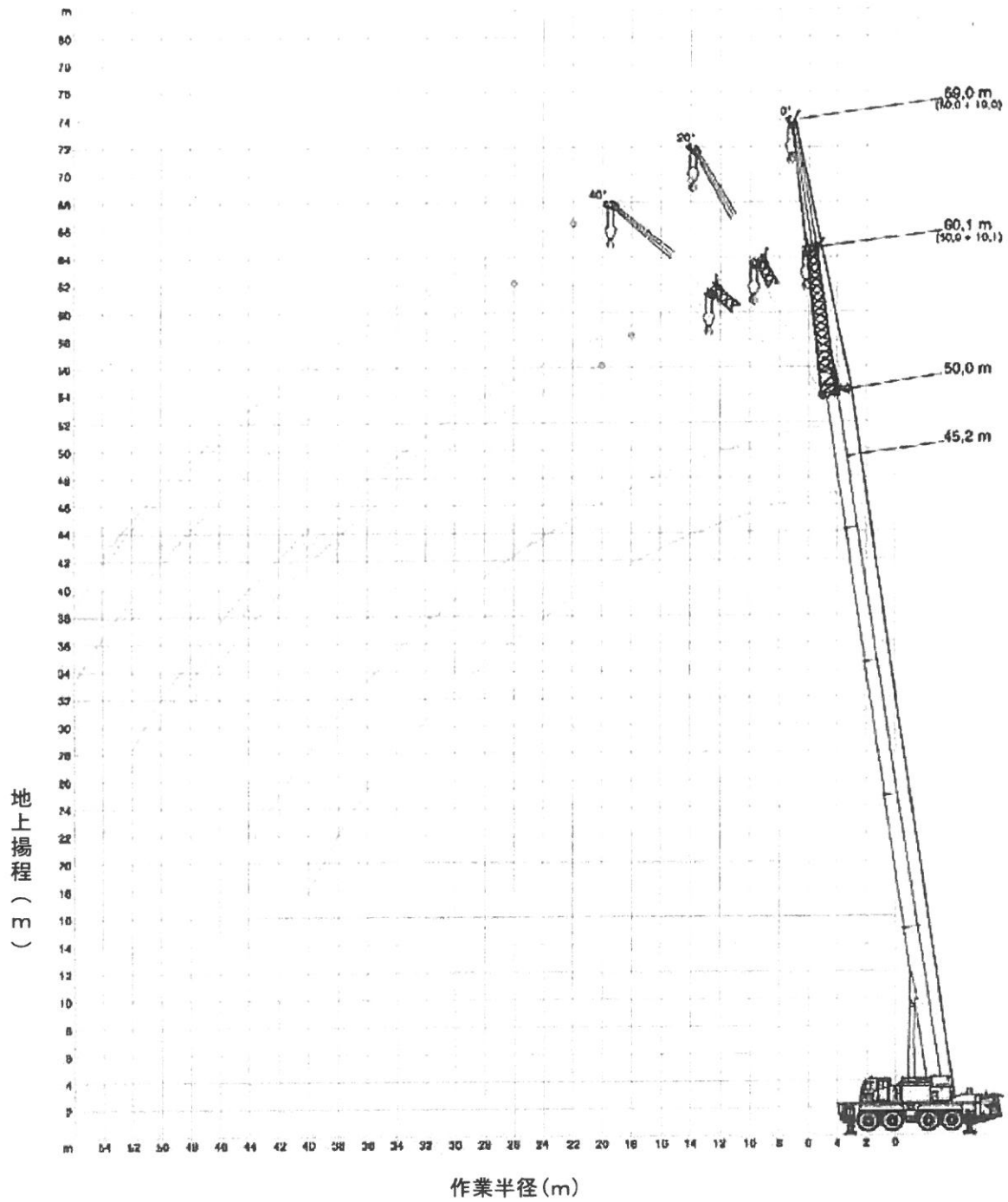

TEREX AC120/4J

油圧チルトジブ定格総荷重表

アウトリガ7.2m張出

26.1 t 8.10 m x 7.20 m 360° ISO

50.0 m

m	10.1 m			19.0 m		
	0°	20°	40°	0°	20°	40°
12	6.7	-	-	-	-	-
14	6.7	-	-	3.7	-	-
16	6.7	-	-	3.7	-	-
18	6.7	6.7	-	3.7	-	-
20	6.7	6.4	5.9	3.7	-	-
22	6.3	6.1	5.7	3.7	3.7	-
24	5.9	5.8	5.4	3.7	3.7	-
26	5.6	5.5	5.2	3.7	3.6	3.3
28	5.2	5.2	5.0	3.7	3.6	3.2
30	4.9	4.9	4.8	3.7	3.5	3.2
32	4.4	4.7	4.6	3.6	3.4	3.1
34	3.8	4.2	4.4	3.5	3.2	3.0
36	3.3	3.6	3.8	3.3	3.1	2.9
38	2.9	3.2	3.3	3.0	3.0	2.8
40	2.5	2.7	2.9	2.6	2.8	2.7
42	2.1	2.4	2.5	2.3	2.7	2.7
44	1.8	2.0	2.1	2.0	2.4	2.6
46	1.6	1.7	1.8	1.7	2.0	2.3
48	1.3	1.4	1.5	1.4	1.7	2.0
50	1.1	1.2	-	1.2	1.5	1.7
52	0.9	1.0	-	1.0	1.2	1.4
54	-	0.7	-	0.7	1.0	1.1
56	-	-	-	-	0.8	0.9

45.2 m

m	10.1 m			19.0 m		
	0°	20°	40°	0°	20°	40°
12	8.6	-	-	-	-	-
14	8.5	-	-	4.6	-	-
16	8.4	8.2	-	4.6	-	-
18	8.2	7.9	7.2	4.6	-	-
20	7.7	7.5	7.1	4.5	4.2	-
22	7.2	7.1	7.0	4.4	4.1	-
24	6.7	6.7	6.7	4.3	4.0	3.5
26	6.2	6.3	6.3	4.2	3.9	3.4
28	5.8	6.8	5.9	4.1	3.8	3.1
30	5.1	5.5	5.5	4.0	3.7	3.3
32	4.5	4.8	5.1	3.9	3.7	3.3
34	4.2	4.2	4.4	3.7	3.6	3.2
36	3.7	3.9	4.0	3.6	3.5	3.2
38	3.2	3.5	3.6	3.2	3.3	3.1
40	2.8	3.0	3.1	3.0	3.2	3.1
42	2.5	2.7	2.7	2.6	2.8	3.0
44	2.2	2.3	2.4	2.3	2.6	2.7
46	1.9	2.0	-	2.0	2.3	2.5
48	1.6	1.7	-	1.7	2.0	2.2
50	1.4	1.5	-	1.5	1.7	1.9
52	-	-	-	1.3	1.5	1.6
54	-	-	-	1.1	1.3	-
56	-	-	-	0.9	1.1	-
58	-	-	-	0.7	0.8	-

41.8 m

m	10.1 m			19.0 m		
	0°	20°	40°	0°	20°	40°
10	10.9	-	-	-	-	-
12	10.7	-	-	5.4	-	-
14	10.4	9.3	-	5.3	-	-
16	10.0	9.0	7.7	5.2	-	-
18	9.3	8.7	7.6	5.1	4.7	-
20	8.6	8.3	7.4	5.0	4.5	-
22	7.9	7.8	7.2	4.8	4.4	-
24	7.3	7.2	6.9	4.7	4.2	3.6
26	6.6	6.7	6.7	4.6	4.1	3.5
28	6.0	6.1	6.3	4.4	4.0	3.5
30	5.4	5.5	5.6	4.3	3.9	3.4
32	4.7	5.1	5.2	4.2	3.8	3.3
34	4.2	4.4	4.6	4.0	3.7	3.3
36	3.7	3.9	4.1	3.7	3.6	3.3
38	3.2	3.4	3.6	3.4	3.5	3.2
40	2.8	3.0	3.1	3.0	3.4	3.2
42	2.5	2.6	-	2.7	3.0	3.2
44	2.2	2.3	-	2.3	2.7	2.9
46	1.9	2.0	-	2.0	2.3	2.5
48	-	-	-	1.8	2.0	2.2
50	-	-	-	1.5	1.8	1.9
52	-	-	-	1.3	1.5	-
54	-	-	-	1.1	1.3	-

11.9 m

m	10.1 m			19.0 m		
	0°	20°	40°	0°	20°	40°
3	13.4	-	-	9.0	-	-
4	13.4	-	-	8.8	-	-
5	13.4	13.4	-	8.6	-	-
6	13.4	12.8	-	8.5	-	-
7	13.3	12.0	-	8.2	-	-
8	12.9	11.4	9.5	8.0	-	-
9	12.5	10.8	9.1	7.7	-	-
10	12.1	10.3	8.7	7.4	6.5	-
12	11.0	9.3	8.1	6.9	5.9	-
14	9.8	8.5	7.7	6.3	5.5	-
16	8.8	7.9	7.5	5.7	5.0	4.3
18	7.9	7.5	-	5.3	4.7	4.1
20	-	-	-	4.9	4.4	3.9
22	-	-	-	4.5	4.1	3.7
24	-	-	-	4.2	3.9	3.7
26	-	-	-	3.9	3.8	-

1. 定格総荷重は、本体を水平堅土上に設置し、フックブロックの自重を含む。
2. 作業半径は、クレーンの旋回中心から荷重の重心までの水平距離です。

TEREX AC120/4J

油圧チルトジブ定格総荷重表

アウトリガ7.2m張出

21.3 t 8.10 m x 7.20 m 360° ISO

50.0 m

m	10.1 m			19.0 m		
	0°	20°	40°	0°	20°	40°
12	6.7	-	-	-	-	-
14	6.7	-	-	3.7	-	-
16	6.7	-	-	3.7	-	-
18	6.7	6.7	-	3.7	-	-
20	6.7	6.4	5.9	3.7	-	-
22	6.3	6.1	5.7	3.7	3.7	-
24	5.9	5.8	5.4	3.7	3.7	-
26	5.6	5.5	5.2	3.7	3.6	3.3
28	4.8	5.2	5.0	3.7	3.6	3.2
30	4.1	4.5	4.8	3.7	3.5	3.2
32	3.5	3.9	4.2	3.6	3.4	3.1
34	3.0	3.4	3.6	3.1	3.2	3.0
36	2.6	2.9	3.1	2.7	3.1	2.9
38	2.2	2.5	2.6	2.3	2.8	2.8
40	1.8	2.1	2.2	2.0	2.4	2.7
42	1.5	1.7	1.9	1.6	2.1	2.4
44	1.2	1.4	1.5	1.4	1.8	2.1
46	1.0	1.1	1.2	1.1	1.5	1.7
48	0.7	0.9	0.9	0.9	1.2	1.4
50	-	-	-	-	0.9	1.1
52	-	-	-	-	0.7	0.9

45.2 m

m	10.1 m			19.0 m		
	0°	20°	40°	0°	20°	40°
12	8.6	-	-	4.6	-	-
14	8.5	-	-	4.6	-	-
16	8.4	8.2	-	4.6	-	-
18	8.2	7.9	7.2	4.6	-	-
20	7.7	7.5	7.1	4.5	4.2	-
22	7.2	7.1	7.0	4.4	4.1	-
24	6.6	6.7	6.7	4.3	4.0	3.5
26	5.7	6.1	6.3	4.2	3.9	3.4
28	5.2	5.3	5.6	4.1	3.8	3.4
30	4.5	4.8	4.9	4.0	3.7	3.3
32	3.9	4.2	4.4	3.8	3.7	3.3
34	3.4	3.7	3.9	3.5	3.6	3.2
36	2.9	3.2	3.3	3.1	3.4	3.2
38	2.5	2.7	2.9	2.7	3.0	3.1
40	2.2	2.4	2.5	2.3	2.7	2.9
42	1.8	2.0	2.1	2.0	2.4	2.6
44	1.6	1.7	1.8	1.7	2.0	2.3
46	1.3	1.4	-	1.4	1.7	1.9
48	1.1	1.2	-	1.2	1.5	1.6
50	0.9	0.9	-	1.0	1.2	1.4
52	-	-	-	0.8	1.0	1.1
54	-	-	-	-	0.8	-

41.8 m

m	10.1 m			19.0 m		
	0°	20°	40°	0°	20°	40°
10	10.9	-	-	-	-	-
12	10.7	-	-	5.4	-	-
14	10.4	9.3	-	5.3	-	-
16	10.0	9.0	7.7	5.2	-	-
18	9.3	8.7	7.6	5.1	4.7	-
20	8.6	8.3	7.4	5.0	4.5	-
22	7.6	7.8	7.2	4.8	4.4	-
24	6.9	6.9	6.9	4.7	4.2	3.6
26	6.0	6.3	6.3	4.6	4.1	3.5
28	5.2	5.6	5.8	4.4	4.0	3.5
30	4.5	4.8	5.1	4.3	3.9	3.4
32	3.9	4.2	4.4	4.0	3.8	3.3
34	3.4	3.6	3.8	3.6	3.7	3.3
36	2.9	3.2	3.3	3.1	3.5	3.3
38	2.5	2.7	2.9	2.7	3.1	3.2
40	2.2	2.3	2.4	2.3	2.7	3.0
42	1.9	2.0	-	2.0	2.4	2.6
44	1.6	1.7	-	1.7	2.0	2.3
46	1.3	1.4	-	1.5	1.7	1.9
48	-	-	-	1.2	1.5	1.6
50	-	-	-	1.0	1.2	1.3
52	-	-	-	0.8	1.0	-
54	-	-	-	-	0.8	-

11.9 m

m	10.1 m			19.0 m		
	0°	20°	40°	0°	20°	40°
3	13.4	-	-	9.0	-	-
4	13.4	-	-	8.8	-	-
5	13.4	13.4	-	8.6	-	-
6	13.4	12.8	-	8.5	-	-
7	13.3	12.0	-	8.2	-	-
8	12.9	11.4	9.5	8.0	-	-
9	12.5	10.8	9.1	7.7	-	-
10	12.1	10.3	8.7	7.4	6.5	-
12	11.0	9.3	8.1	6.9	5.9	-
14	9.8	8.5	7.7	6.3	5.5	-
16	8.8	7.9	7.5	5.7	5.0	4.3
18	7.9	7.5	-	5.3	4.7	4.1
20	-	-	-	4.9	4.4	3.9
22	-	-	-	4.5	4.1	3.7
24	-	-	-	4.2	3.9	3.7
26	-	-	-	3.9	3.8	-

1. 定格総荷重は、本体を水平堅土上に設置し、フックブロックの自重を含む。
2. 作業半径は、クレーンの旋回中心から荷重の重心までの水平距離です。

TEREX AC120/4J

油圧チルトジブ定格総荷重表

アウトリガ6.0m張出

26.1 t 8.10 m x 6.00 m 360° ISO

50.0 m

m	10.1 m			19.0 m		
	0°	20°	40°	0°	20°	40°
12	6.7	-	-	-	-	-
14	6.7	-	-	3.7	-	-
16	6.7	-	-	3.7	-	-
18	6.7	6.7	-	3.7	-	-
20	6.7	6.4	5.9	3.7	-	-
22	6.3	6.1	5.7	3.7	3.7	-
24	5.8	5.8	5.4	3.7	3.7	-
26	5.0	5.3	5.2	3.7	3.6	3.3
28	4.3	4.6	4.9	3.7	3.6	3.2
30	3.7	4.0	4.3	3.7	3.5	3.2
32	3.2	3.5	3.7	3.4	3.4	3.1
34	2.8	3.1	3.2	2.9	3.2	3.0
36	2.4	2.7	2.8	2.6	3.0	2.9
38	2.1	2.3	2.5	2.2	2.6	2.8
40	1.8	2.0	2.1	1.9	2.3	2.6
42	1.5	1.7	1.8	1.6	2.0	2.2
44	1.2	1.4	1.5	1.3	1.7	1.9
46	0.9	1.1	1.2	1.0	1.4	1.7
48	0.7	0.8	0.9	0.8	1.1	1.4
50	-	-	-	-	0.9	1.1
52	-	-	-	-	-	0.8

45.2 m

m	10.1 m			19.0 m		
	0°	20°	40°	0°	20°	40°
12	8.6	-	-	4.6	-	-
14	8.5	-	-	4.6	-	-
16	8.4	8.2	-	4.6	-	-
18	8.2	7.9	7.2	4.6	-	-
20	7.7	7.5	7.1	4.5	4.2	-
22	6.8	7.1	7.0	4.4	4.1	-
24	6.0	6.2	6.5	4.3	4.0	3.5
26	5.2	5.5	5.7	4.2	3.9	3.4
28	4.6	4.9	5.0	4.1	3.8	3.4
30	4.0	4.3	4.5	3.9	3.7	3.3
32	3.5	3.7	3.9	3.6	3.7	3.3
34	3.1	3.3	3.4	3.2	3.5	3.2
36	2.7	2.9	3.0	2.8	3.1	3.2
38	2.4	2.5	2.6	2.5	2.8	3.0
40	2.1	2.2	2.3	2.2	2.5	2.7
42	1.8	1.9	2.0	1.9	2.2	2.4
44	1.5	1.7	1.7	1.6	1.9	2.1
46	1.3	1.4	-	1.4	1.7	1.9
48	1.0	1.1	-	1.1	1.4	1.6
50	0.8	0.9	-	0.9	1.2	1.3
52	-	-	-	0.8	1.0	1.1
54	-	-	-	-	0.7	-

41.8 m

m	10.1 m			19.0 m		
	0°	20°	40°	0°	20°	40°
10	10.9	-	-	-	-	-
12	10.7	-	-	5.4	-	-
14	10.4	9.3	-	5.3	-	-
16	10.0	9.0	7.7	5.2	-	-
18	9.3	8.7	7.6	5.1	4.7	-
20	8.0	8.3	7.4	5.0	4.5	-
22	7.0	7.3	7.2	4.8	4.4	-
24	6.0	6.4	6.6	4.7	4.2	3.6
26	5.2	5.6	5.8	4.6	4.1	3.5
28	4.6	4.9	5.1	4.4	4.0	3.5
30	4.0	4.3	4.4	4.1	3.9	3.4
32	3.5	3.7	3.9	3.7	3.8	3.3
34	3.1	3.3	3.4	3.2	3.6	3.3
36	2.7	2.9	3.0	2.8	3.2	3.3
38	2.4	2.5	2.6	2.5	2.8	3.1
40	2.1	2.2	2.3	2.2	2.5	2.7
42	1.8	1.9	-	1.9	2.2	2.4
44	1.5	1.7	-	1.7	1.9	2.1
46	1.3	1.4	-	1.4	1.7	1.8
48	-	-	-	1.2	1.4	1.6
50	-	-	-	1.0	1.2	1.3
52	-	-	-	0.8	1.0	-
54	-	-	-	-	0.7	-

11.9 m

m	10.1 m			19.0 m		
	0°	20°	40°	0°	20°	40°
3	13.4	-	-	9.0	-	-
4	13.4	-	-	8.8	-	-
5	13.4	13.4	-	8.6	-	-
6	13.4	12.8	-	8.5	-	-
7	13.3	12.0	-	8.2	-	-
8	12.9	11.4	9.5	8.0	-	-
9	12.5	10.8	9.1	7.7	-	-
10	12.1	10.3	8.7	7.4	6.5	-
12	11.0	9.3	8.1	6.9	5.9	-
14	9.8	8.5	7.7	6.3	5.5	-
16	8.8	7.9	7.5	5.7	5.0	4.3
18	7.9	7.5	-	5.3	4.7	4.1
20	-	-	-	4.9	4.4	3.9
22	-	-	-	4.5	4.1	3.7
24	-	-	-	4.2	3.9	3.7
26	-	-	-	3.9	3.8	-

1. 定格総荷重は、本体を水平堅土上に設置し、フックブロックの自重を含む。
2. 作業半径は、クレーンの旋回中心から荷重の重心までの水平距離です。

TEREX AC120/4J

油圧チルトジブ定格総荷重表

アウトリガ6.0m張出

21.3 t 8.10 m x 6.00 m 360° ISO

50.0 m

m	10.1 m			19.0 m		
	0°	20°	40°	0°	20°	40°
12	6.7	-	-	-	-	-
14	6.7	-	-	3.7	-	-
16	6.7	-	-	3.7	-	-
18	6.7	6.7	-	3.7	-	-
20	6.7	6.4	5.9	3.7	-	-
22	5.6	6.1	5.7	3.7	3.7	-
24	4.8	5.2	5.4	3.7	3.7	-
26	4.1	4.5	4.8	3.7	3.6	3.3
28	3.5	3.8	4.1	3.6	3.6	3.2
30	3.0	3.3	3.5	3.1	3.5	3.2
32	2.5	2.8	3.0	2.6	3.2	3.1
34	2.2	2.4	2.6	2.2	2.7	3.0
36	1.8	2.0	2.2	1.8	2.4	2.7
38	1.4	1.7	1.9	1.5	2.0	2.3
40	1.1	1.4	1.5	1.2	1.7	2.0
42	0.8	1.1	1.2	1.0	1.4	1.7
44	-	0.8	0.9	0.7	1.1	1.4
46	-	-	-	-	0.8	1.1
48	-	-	-	-	-	0.8

45.2 m

m	10.1 m			19.0 m		
	0°	20°	40°	0°	20°	40°
12	8.6	-	-	4.6	-	-
14	8.5	-	-	4.6	-	-
16	8.4	8.2	-	4.6	-	-
18	8.1	7.9	7.2	4.6	-	-
20	7.0	7.3	7.1	4.5	4.2	-
22	5.9	6.2	6.5	4.4	4.1	-
24	5.1	5.4	5.6	4.3	4.0	3.5
26	4.3	4.7	5.0	4.2	3.9	3.4
28	3.7	4.1	4.3	3.9	3.8	3.4
30	3.2	3.5	3.7	3.4	3.7	3.3
32	2.8	3.0	3.2	2.9	3.4	3.3
34	2.4	2.6	2.8	2.5	3.0	3.2
36	2.1	2.3	2.4	2.2	2.6	2.9
38	1.8	2.0	2.1	1.9	2.2	2.5
40	1.5	1.7	1.8	1.6	1.9	2.2
42	1.2	1.3	1.4	1.3	1.7	1.9
44	0.9	1.1	1.1	1.0	1.4	1.6
46	0.7	0.8	-	0.8	1.1	1.3
48	-	-	-	-	0.9	1.1
50	-	-	-	-	-	0.8

41.8 m

m	10.1 m			19.0 m		
	0°	20°	40°	0°	20°	40°
10	10.9	-	-	-	-	-
12	10.7	-	-	5.4	-	-
14	10.4	9.3	-	5.3	-	-
16	9.7	9.0	7.7	5.2	-	-
18	8.4	8.6	7.6	5.1	4.7	-
20	7.0	7.5	7.4	5.0	4.5	-
22	5.9	6.4	6.7	4.8	4.4	-
24	5.1	5.4	5.7	4.7	4.2	3.6
26	4.3	4.7	4.9	4.4	4.1	3.5
28	3.7	4.0	4.3	3.9	4.0	3.5
30	3.2	3.5	3.7	3.4	3.8	3.4
32	2.8	3.0	3.2	2.9	3.4	3.3
34	2.4	2.6	2.8	2.6	3.0	3.3
36	2.1	2.3	2.4	2.2	2.6	2.9
38	1.8	1.9	2.0	1.9	2.3	2.5
40	1.5	1.6	1.7	1.6	2.0	2.2
42	1.2	1.3	-	1.3	1.7	1.9
44	0.9	1.1	-	1.1	1.4	1.6
46	0.7	0.8	-	0.9	1.1	1.3
48	-	-	-	-	0.9	1.0
50	-	-	-	-	-	0.8

11.9 m

m	10.1 m			19.0 m		
	0°	20°	40°	0°	20°	40°
3	13.4	-	-	9.0	-	-
4	13.4	-	-	8.8	-	-
5	13.4	13.4	-	8.6	-	-
6	13.4	12.8	-	8.5	-	-
7	13.3	12.0	-	8.2	-	-
8	12.9	11.4	9.5	8.0	-	-
9	12.5	10.8	9.1	7.7	-	-
10	12.1	10.3	8.7	7.4	6.5	-
12	11.0	9.3	8.1	6.9	5.9	-
14	9.8	8.5	7.7	6.3	5.5	-
16	8.8	7.9	7.5	5.7	5.0	4.3
18	7.9	7.5	-	5.3	4.7	4.1
20	-	-	-	4.9	4.4	3.9
22	-	-	-	4.5	4.1	3.7
24	-	-	-	4.2	3.9	3.7
26	-	-	-	3.9	3.8	-

1. 定格総荷重は、本体を水平堅土上に設置し、フックブロックの自重を含む。
2. 作業半径は、クレーンの旋回中心から荷重の重心までの水平距離です。